

# NE-CUBE MINI+ PRINT & ASSEMBLY INSTRUCTIONS

---

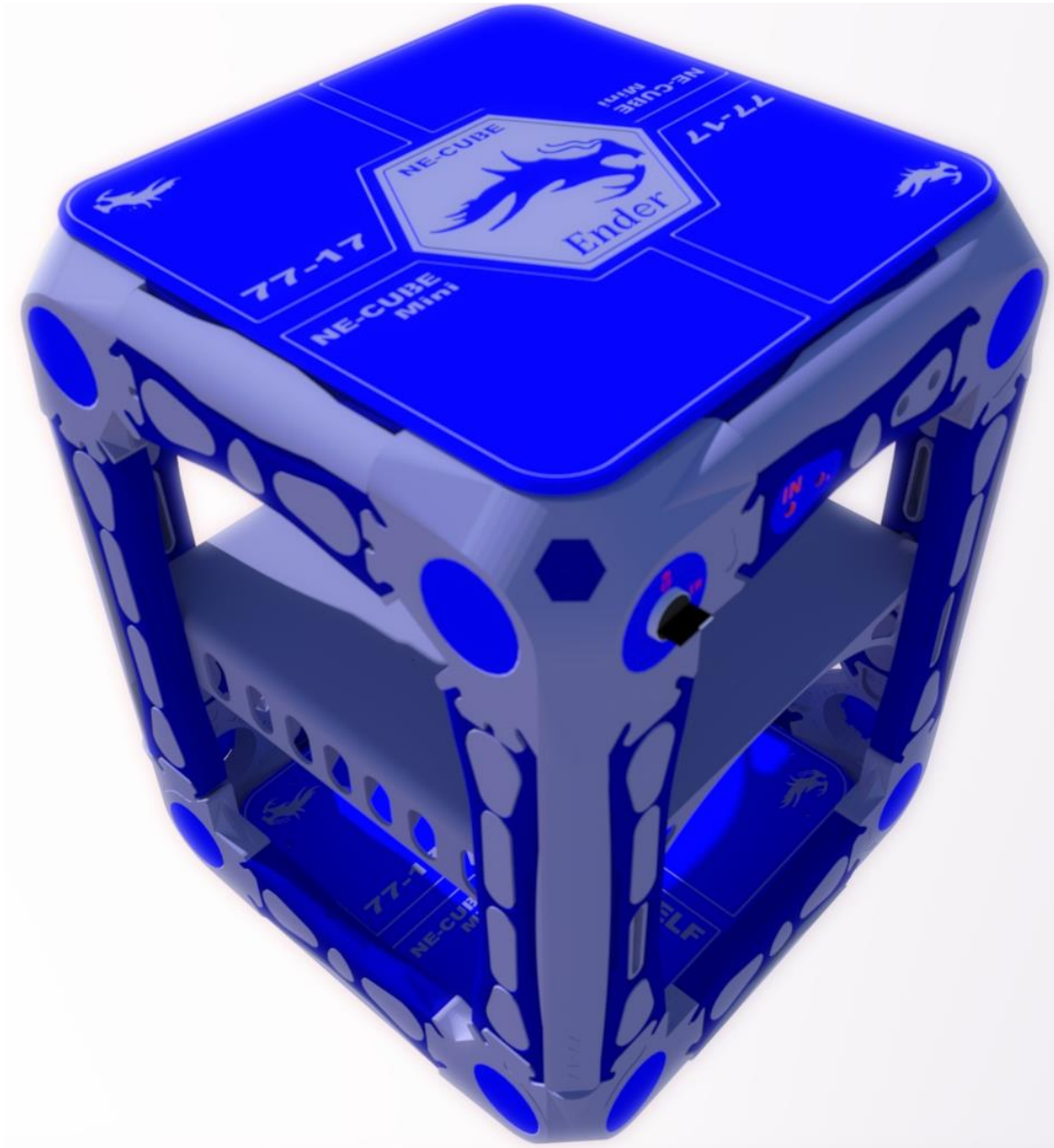

## NE-CUBE MINI+ 3D PRINTER STAND / GENERAL USE INTERLOCKING CUBE / TABLE

- INCLUDES INSTRUCTIONS TO PRINT AND ASSEMBLE TOP & CORE STRUCTURE.
- OPTIMIZED FOR CREALITY CR10 3D PRINTERS.
- .6 TO 1 MM PRINTER NOZEL RECOMMENDED.

DESIGNED IN ONTARIO CANADA JULY 2021 BY 77-17

# INDEX

- PRODUCT DESCRIPTION
- PARTS LIST
- CORE BILL OF MATERIALS
- PRINT SETTINGS
- POST PRINT PREP INSTRUCTIONS
- ASSEMBLY INSTRUCTIONS

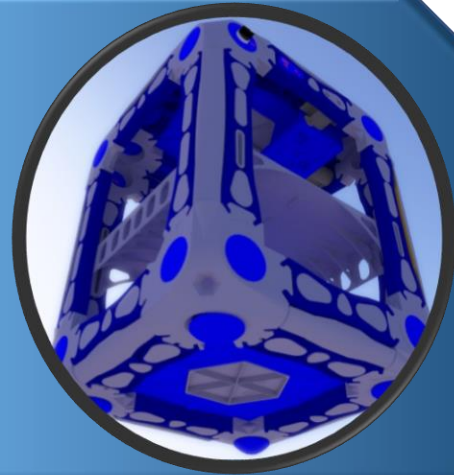

## DESCRIPTION

- ✓ Interlocking 19 ½" x 19 ½" x 25 ½" Heavy Duty Cube / Table / Stand
- ✓ Reduced material / Increased strength.
- ✓ 300 x 300 X-Y Build volume Required.

## PARTS LIST

CORN

UNLOCKED

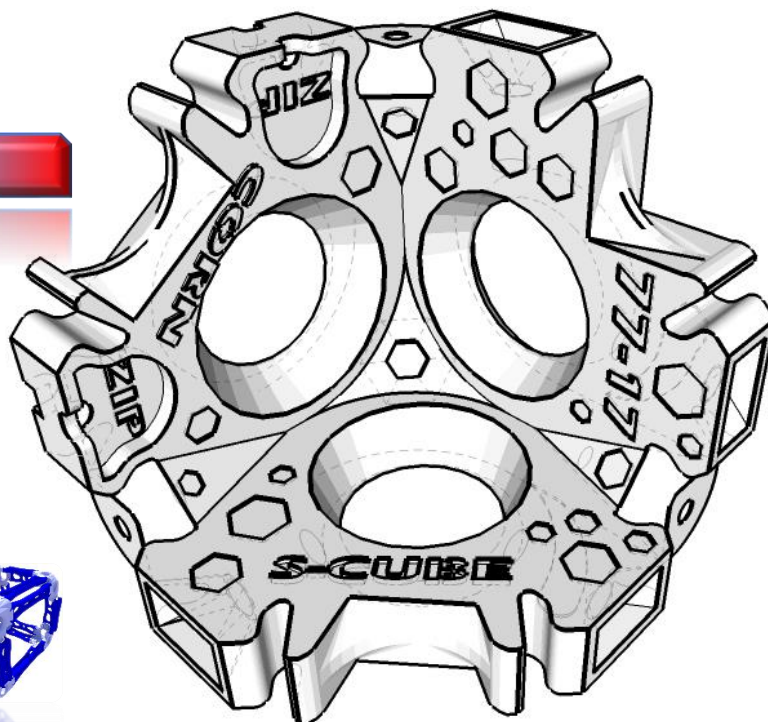

X8

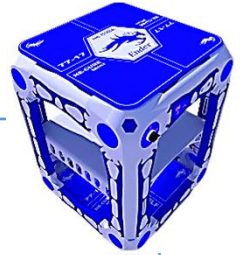

**STRETCH**

**UNLOCKED**

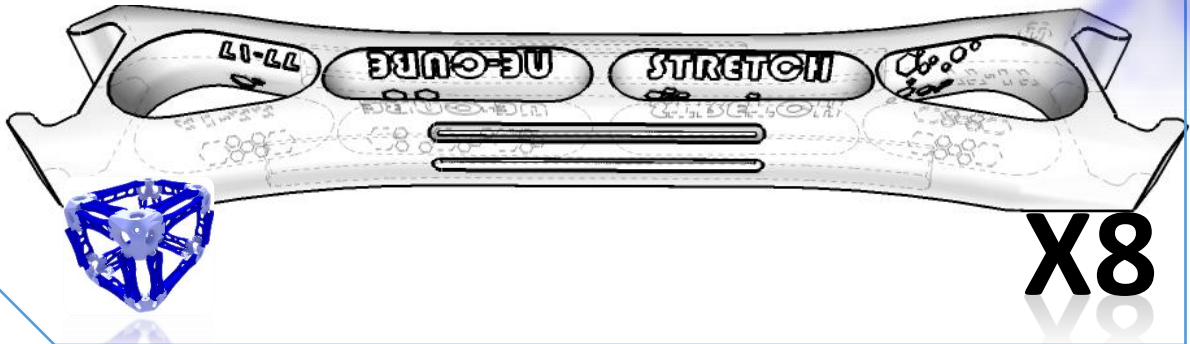

**X8**

**STEEZ**

**UNLOCKED**

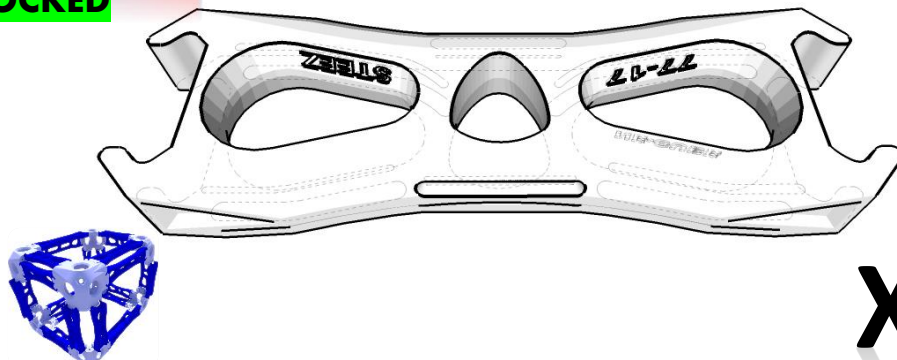

**X16**

**STAN**

**UNLOCKED**

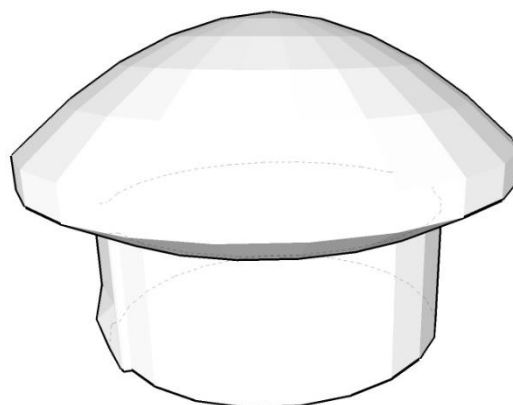
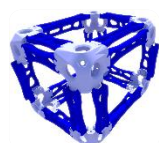

**X4**



**XT1**

**LOCKED**

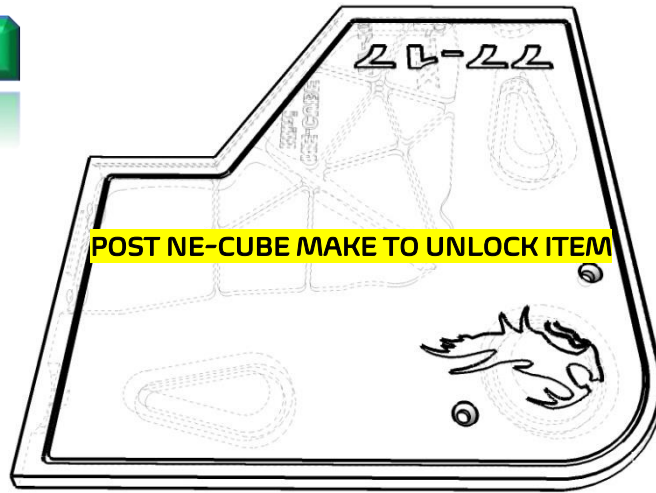

**X2**

**XT2**

**LOCKED**

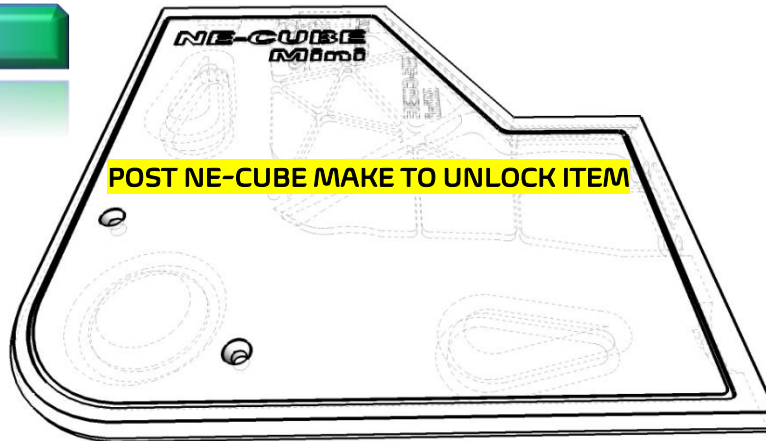

**X2**

**XT3**

**LOCKED**

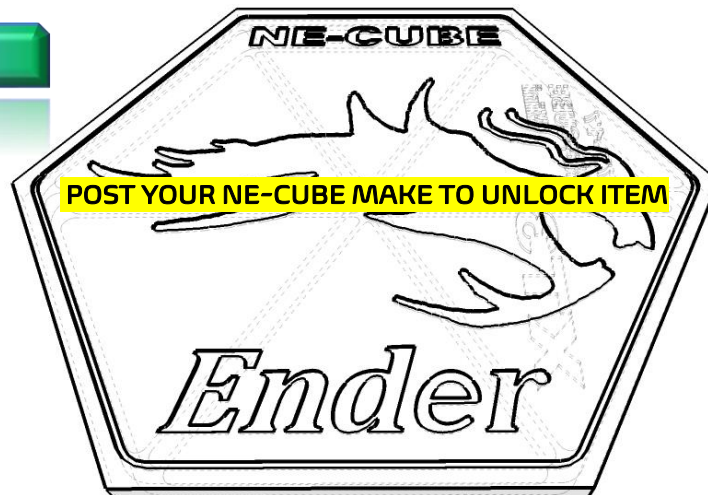

**X1**



**XT1S**

**LOCKED**

POST YOUR NE-CUBE MAKE WITH XT1, XT2 & XT3 TO UNLOCK ITEM

**X2**

**XT2S**

**LOCKED**

POST YOUR NE-CUBE MAKE WITH XT1, XT2 & XT3 TO UNLOCK ITEM

**X2**

**XT3S**

**LOCKED**

POST YOUR NE-CUBE MAKE WITH XT1, XT2 & XT3 TO UNLOCK ITEM

**X1**

**XS1**

**LOCKED**

POST YOUR NE-CUBE MAKE WITH XT1, XT2 & XT3 TO UNLOCK

**X2**

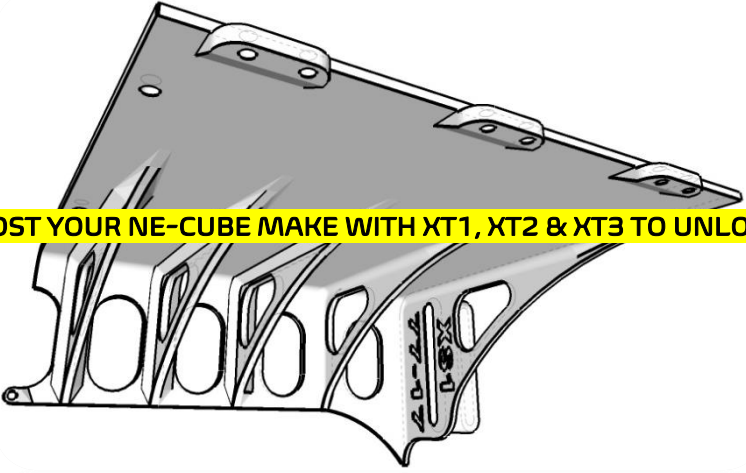
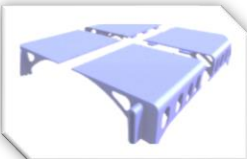



**XS2**

**LOCKED**

POST YOUR NE-CUBE MAKE WITH XT1, XT2 & XT3 TO UNLOCK

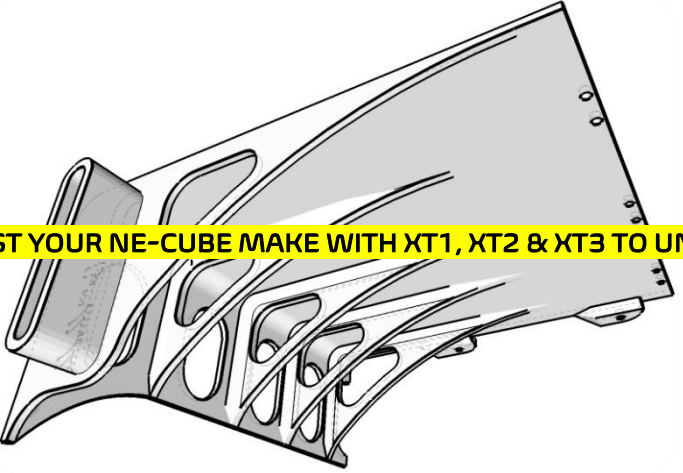
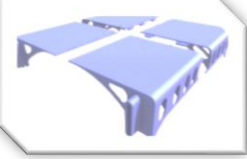
**X2**

**BLUETOOTH**

**\$5 CAD PURCHASE**

**X2**



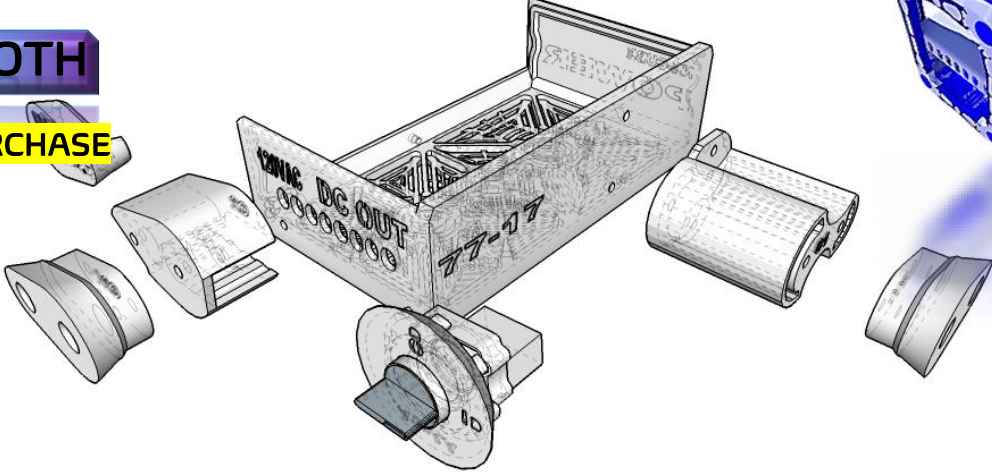

# BODY KIT

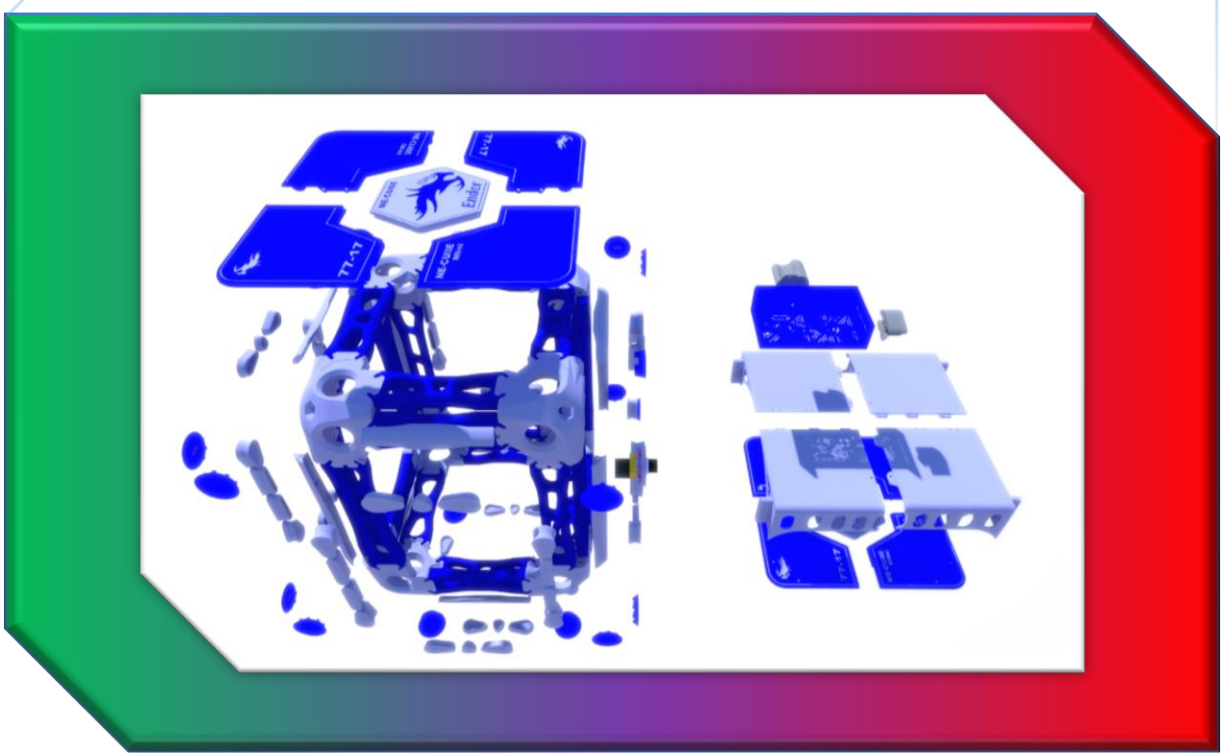
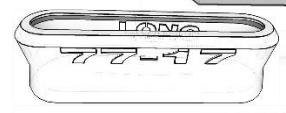
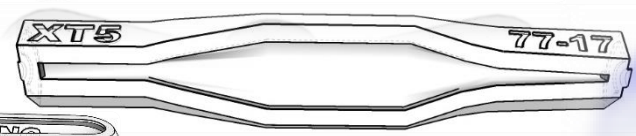
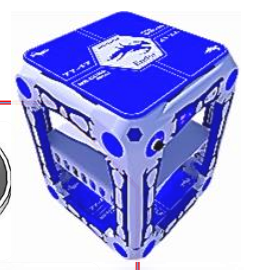
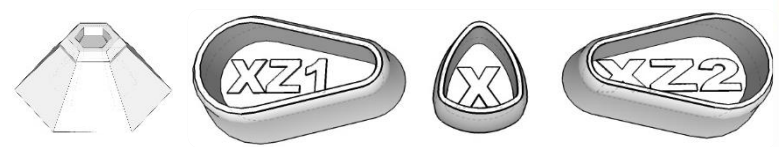
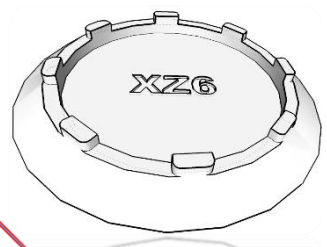
\$2 CAD PURCHASE

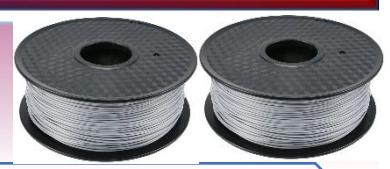

# Bill Of Materials



STRETCH	x 8	.334 KG
STEEZ	x16	.118 KG
CORN	x 8	.175 KG
STAN	x 4	.041 KG

2.7 KG
1.9 KG
1.4 KG
.2 KG



# PRINT SETTINGS









cura

Print settings



Profile: Draft Quality - 0.32mm

Search settings

### Quality



Layer Height	 	0.3	mm
Initial Layer Height	 	0.4	mm
Line Width		0.8	mm
Wall Line Width	 	0.75	mm
Outer Wall Line Width		0.75	mm
Inner Wall(s) Line Width		0.75	mm
Top/Bottom Line Width	 	0.75	mm
Infill Line Width		0.8	mm
Initial Layer Line Width		100.0	%

### Walls

Wall Thickness	 	1.5	mm
Wall Line Count		2	
Outer Wall Inset		0.025	mm
Optimize Wall Printing Order		<input checked="" type="checkbox"/>	



### Walls

Wall Thickness	 	1.5	mm
Wall Line Count		2	
Outer Wall Inset		0.025	mm
Optimize Wall Printing Order		<input checked="" type="checkbox"/>	
Outer Before Inner Walls		<input type="checkbox"/>	
Alternate Extra Wall		<input type="checkbox"/>	
Compensate Wall Overlaps		<input type="checkbox"/>	
Compensate Outer Wall Overlaps		<input type="checkbox"/>	
Compensate Inner Wall Overlaps		<input type="checkbox"/>	
Fill Gaps Between Walls		Everywhere	
Filter Out Tiny Gaps		<input checked="" type="checkbox"/>	
Print Thin Walls		<input checked="" type="checkbox"/>	
Horizontal Expansion		0.0	mm

### Top/Bottom

Top Surface Skin Layers		1	
Top/Bottom Thickness	 	1.0	mm
Top Thickness		1.0	mm
Top Layers		4	
Bottom Thickness		1.0	mm
Bottom Layers		4	
Top/Bottom Pattern		Lines	
Bottom Pattern Initial Layer		Lines	
Top/Bottom Line Directions		[ ]	
Extra Skin Wall Count	 	0	
Enable Ironing		<input type="checkbox"/>	
Skin Overlap Percentage		10.0	%
Skin Overlap		0.075	mm

### Infill

Infill Density	↻	25.0	%
Infill Pattern	↻ ⚙️	Cubic Subdivision	▼
Randomize Infill Start		<input type="checkbox"/>	
Extra Infill Wall Count		0	
Cubic Subdivision Shell		0.75	mm
Infill Overlap Percentage	↻	15.0	%
Infill Overlap		0.1163	mm
Infill Wipe Distance		0.0	mm
Infill Layer Thickness		0.3	mm
Infill Before Walls		<input type="checkbox"/>	
Minimum Infill Area		0.0	mm <sup>2</sup>
Infill Support		<input type="checkbox"/>	
Skin Edge Support Thickness	↻ ⚙️	0.5	mm
Skin Edge Support Layers	↻ ⚙️	1	

### Material

Printing Temperature	↻ ⚙️	220.0	°C
Printing Temperature Initial Layer		220.0	°C
Initial Printing Temperature		220.0	°C
Final Printing Temperature		220.0	°C
Build Plate Temperature	🔗 ↻	65.0	°C
Build Plate Temperature Initial Layer	🔗	65	°C
Flow		100.0	%
Wall Flow		100.0	%
Outer Wall Flow		100.0	%
Inner Wall(s) Flow		100.0	%
Top/Bottom Flow		100.0	%
Top Surface Skin Flow	↻ ⚙️	99.0	%
Infill Flow	↻ ⚙️	99.0	%
Initial Layer Flow	↻	75.0	%

### Speed

Print Speed		55.0	mm/s
Infill Speed		50.0	mm/s
Wall Speed		27.5	mm/s
Outer Wall Speed		68.0	mm/s
Inner Wall Speed		70.0	mm/s
Top Surface Skin Speed		20.0	mm/s
Top/Bottom Speed		45.0	mm/s
Travel Speed		150.0	mm/s
Initial Layer Speed		30.0	mm/s
Initial Layer Print Speed		30.0	mm/s
Initial Layer Travel Speed		150.0	mm/s
Z Hop Speed		10.0	mm/s
Number of Slower Layers		1	
Equalize Filament Flow		<input type="checkbox"/>	

### Support

Generate Support		<input type="checkbox"/>	
<b>Build Plate Adhesion</b>			
Build Plate Adhesion Type		None	
<b>Dual Extrusion</b>			
<b>Mesh Fixes</b>			
<b>Special Modes</b>			
<b>Experimental</b>			
Top Surface Skin Line Width		0.75	mm
Top Surface Skin Pattern		Lines	
Top Surface Skin Line Directions		[ ]	
Make Overhang Printable		<input type="checkbox"/>	
Enable Coasting		<input type="checkbox"/>	
Fuzzy Skin		<input type="checkbox"/>	
Use Adaptive Layers		<input checked="" type="checkbox"/>	

# POST PRINT PREP

- ✓ CHAMFER FACE EDGES CONTACTING PRINT BED
- ✓ VERIFY SMOOTH FIT MAINTAINED BETWEEN MAITING PARTS  
USE RAZOR / FILE / SANDPAPER IF NEEDED

# ASSEMBLY INSTRUCTIONS

1. VERIFY 36 PCS ACCOUNTED FOR
2. KEEP CORN ORIENTATION ON ONE SIDE ASSEMBLED FACE
3. SLIDE STEEZ HORIZONTALY ONTO 4 CORN PIECES SET IN A SQUARE
4. ASSEMBLE 2 SQUARES USING 8 STEEZ & 4 CORN EACH
5. CONNECT THE 2 SQUARES USING 8 STRETCH
6. CRAZY GLUE JOINTS FOR PERMANACE
7. LEAVE 2 STRETCH FREE OF GLUE FOR SHELF INSTALLATION
8. POST YOUR NE-CUBE MAKE ON THINGIVERSE TO RECEIVE TOP SURFACE FILES
9. POST PICTURE OF YOUR PRINTED NE-CUBE WITH TOP SURFACE ON THINGIVERSE TO RECEIVE XT AND XS FILES
10. MESSAGE 77-17 OR COMMENT ON THING
  - BLUETOOTH RADIO KIT WITH INSTRUCTIONS \$5
  - BODY KIT \$2

WRITTEN IN ONTARIO CANADA JULY 2021 BY 77-17